



BRDV

DİKEY ATIŞLI RADYAL ÇATI FANI Motor Hava Akımının Dışında

BRDV dikey atışlı radyal çatı fanlarında geriye eğimli ve direkt akupleli motor kullanılmaktadır.
Taşınan maksimum hava sıcaklığı 120 °C.
Düşük ses seviyeli.

Teknik Resim

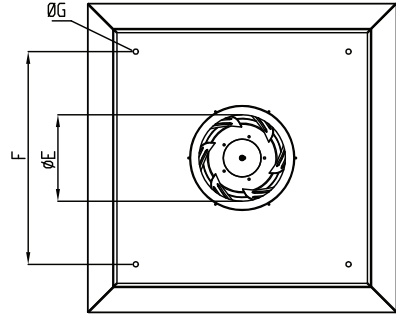
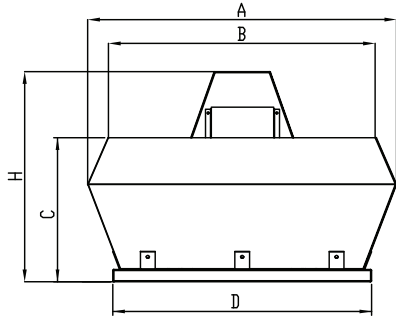

MALZEME

: Gövdesi; Galvaniz sac
Radyal Fan; geriye eğimli kanat yapısı ile galvaniz sacdan üretilmiştir.

YALITIM SINIFI

: Class F

MAX. HAVA TAŞINIMI

: 120°C

STANDART

: EN 60335-1, EN 60335-2-80, EN 12101-3

HIZ KONTROLÜ

: Opsiyonel kontrol cihazlarıyla sağlanabilir.

KULLANIM ALANLARI

: BRDV serisi fanlar yaşamsal, endüstriyel ve ticari alanlarda; daha yüksek sıcaklarda hava, duman vs.'nin tahliyesi uygulamalarında mükemmel çözümler sunar.

Aksesuarlar



BSC-F

TİP	VOLTAJ	FREKANS	GÜÇ	AKIM	KONDANSATÖR	DEVİR	DEBİ	SES SEVİYESİ	AĞIRLIK
	V	Hz	KW	(A)	(µF)	d/d	m³/h	dB(A)	kg
BRDV 315	230/380	50	0,25	1,8/0,81	10/-	1420	1700	47	22
BRDV 355	230/380	50	0,37	2,6/1,15	12/-	1410	2500	49	27
BRDV 400	230/380	50	0,37	2,6/1,15	12/-	1400	3600	52	33
BRDV 450	380	50	0,75	2	-	1370	5000	54	38
BRDV 500	380	50	1,5	3,5	-	1350	8000	57	49
BRDV 560	380	50	2,2	5,1	-	1350	10500	65	58

TİP	A	B	C	D	E	F	G	H
BRDV 315	840	730	390	700	185	576	14	575
BRDV 355	840	730	390	700	234	576	14	575
BRDV 400	890	785	425	750	270	576	14	596
BRDV 450	960	850	445	800	282	626	14	655
BRDV 500	1030	910	490	850	320	676	14	720
BRDV 560	1190	960	600	950	360	740	14	850

Ölçüler mm cinsindedir.

